

## **SAFETY GUIDELINES:**

Please read and follow the following safety guidelines:

Before beginning any exercise program, you should consult with your doctor. It is recommended that you undergo a complete physical examination.

- . Read this owner's manual and follow the instructions.
- . Assemble and operate the treadmill on a solid, level surface. Keep the area behind the treadmill clear.
- . Never allow children on or near the treadmill. The treadmill running belt will not stop immediately if any object becomes caught in the belt or rollers.
- . Check the treadmill before every use. Make sure all parts are assembled, and all nuts and bolts are tightened. Do not use the treadmill if the unit is disassembled in any way.
- . Keep hands away from moving parts.
- . The weight limit for this treadmill is 300 LBS. (135 KGS).
- . Wear proper workout clothing: Do not wear loose clothing. Do not wear shoes with leather soles or high heels. Tie back all long hair.
- . Don't rock the unit from side to side. Care should be taken when mounting and dismounting the unit.
- . Straddle the machine with your feet on the right and left staging platforms before starting the running belt.
- . Do not place any liquids on any part of the treadmill.
- . To prevent shock, keep all electric components, such as the motor, cord, and switch away from water.
- . Do not use any accessories that aren't specifically recommended by the manufacturer, these might cause injuries or cause the unit to fail.
- . Work within your recommended exercise level, do NOT work to exhaustion.
- . If you feel any pain or abnormal sensation, STOP YOUR WORKOUT and consult your physician immediately.
- . Turn off the treadmill while adjusting or working near the rear roller.

**Warning**—To reduce the risk of burns, fire, electric shock, or injury to persons:

- . A treadmill should never be left unattended when plugged in. Unplug from outlet when not in use, and before putting on or taking off parts.
- . Close supervision is necessary when this treadmill is used by, on, or near children, invalids, or disabled persons.
- . Use this treadmill only for its intended use as described in this manual.
- . Never operate this treadmill if it has a damaged cord or plug, if it is not working properly, if it has been dropped or damaged, or dropped into water. Return the treadmill to a service center for examination and repair.
- . Do not carry this treadmill by supply cord or use cord as a handle.
- . Keep the cord away from heated surfaces.
- . Never operate the treadmill with the air openings blocked. Keep the air openings free of lint, hair, and the like.
- . Never drop or insert any object into any opening.
- . Do not use outdoors.
- . Do not operate where aerosol (spray) products are being used or where oxygen is being administered.
- . To disconnect, turn all controls to the off position, than remove plug from outlet.
- . Connect this treadmill to a properly grounded outlet only.

The treadmill is designed for the use and enjoyment. By following the above precautions and using good judgment and common sense, you will enjoy safe and pleasurable exercise with this treadmill.

## **TABLE OF CONTENTS**

1. SAFETY GUIDELINES.....	1
2. INTRODUCTION.....	3
3. ASSEMBLING YOUR TREADMILL	
Installation Requirements.....	5
List of parts.....	5
Step by step instructions.....	6
Floor level adjustment.....	8
4. OPERATING INSTRUCTIONS	
Safety key.....	9
5. UNDERSTANDING THE ELECTRONICS PACKAGE	
MANUAL Mode .....	11
SET Mode.....	11
INTERVAL Mode.....	12
PROGRAM Mode.....	14
PAUSE Mode.....	15
General remarks.....	15
6. KEY FUNCTIONS.....	16
What each of the categories means.....	16
7. RUNNING ON THE TREADMILL.....	17
8. GUIDELINES FOR EXERCISE	
How long should I exercise?.....	18
How often should I exercise?.....	18
9. MAINTAINING YOUR TREADMILL	
Cleaning the treadmill.....	18
Adjusting the running belt.....	19
10. TROUBLE SHOOTING	
ERR messages.....	22
Blank display.....	23
Fuse Failure For Electronics Package And Motor.....	23
Fuse Failure For Incline System.....	24
Fuse Failure For Drive Board.....	25

**INTRODUCTION:**

Congratulations on purchasing one of the finest pieces of exercise equipment on the market today. Constructed of high quality materials and designed for years of trouble free usage. We hope the 3100 will be an integral part of your fitness regimen.

Before using your treadmill, we recommend that you familiarize yourself with this Owner's Manual. Whether you are a first time user of a treadmill or a seasoned "pro", understanding the correct use of the equipment will enhance your ability to achieve your exercise goals safely and successfully.

**ITEM:3100**

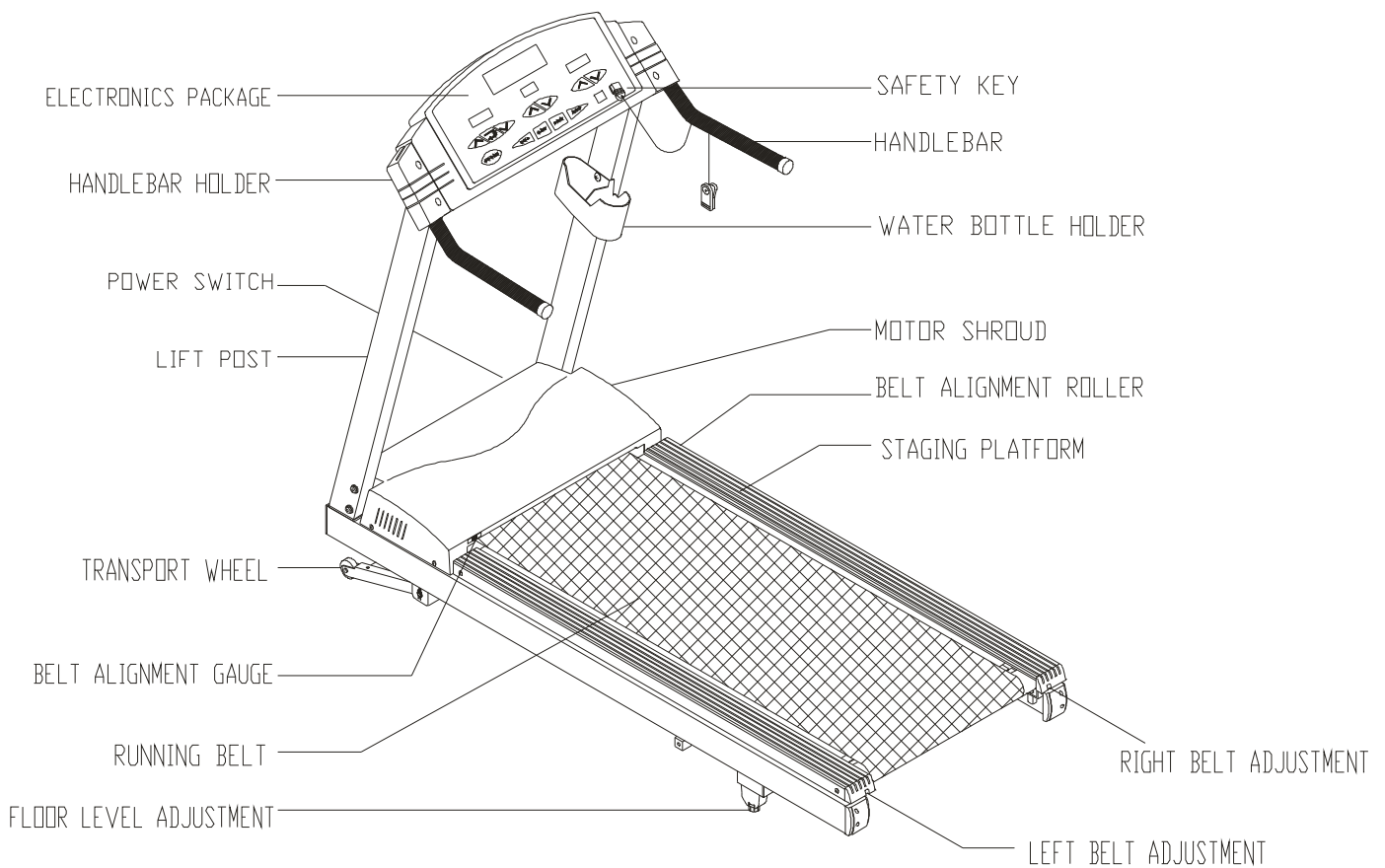

ITEM:3100L

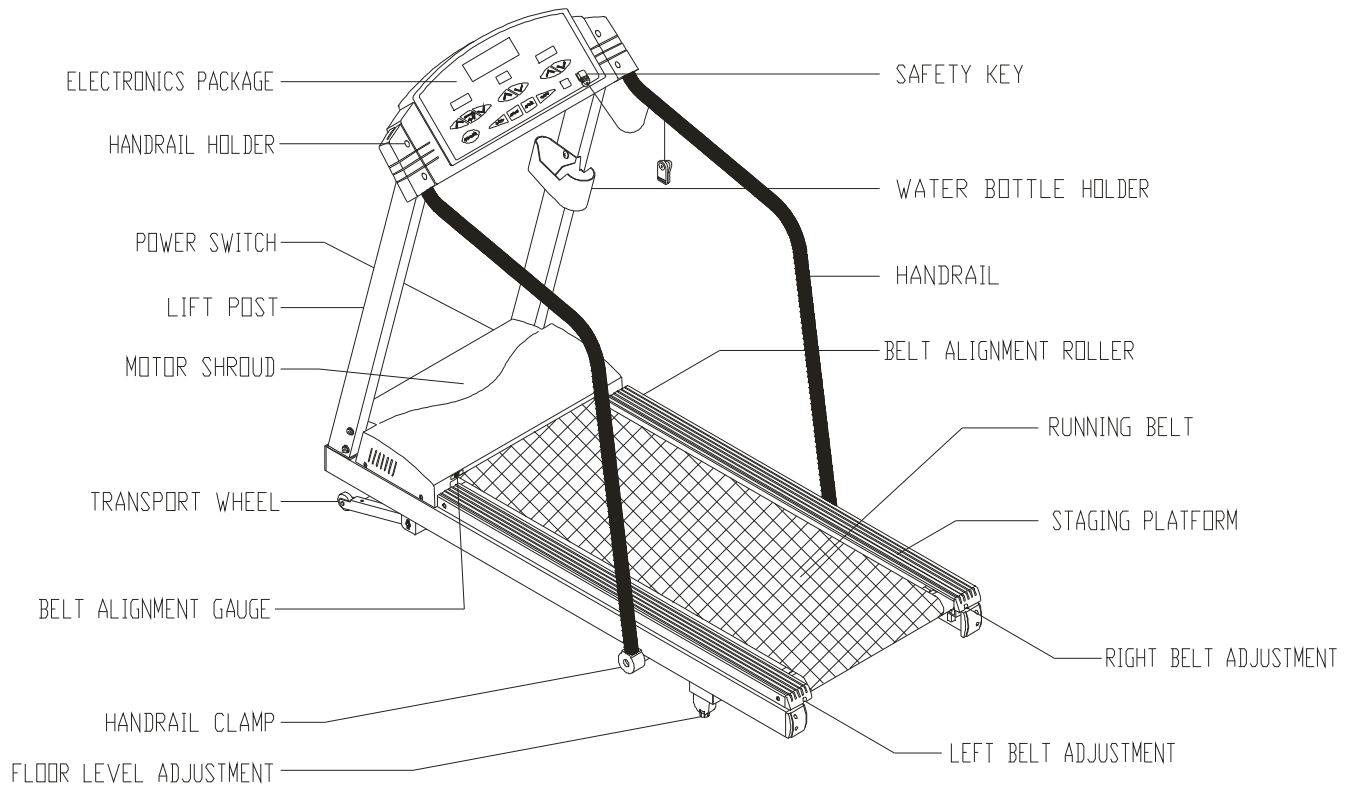

## **ASSEMBLING YOUR TREADMILL:**

### Installation Requirements

Read this owner's manual and follow the instructions contained herein.

**CAUTION:** To avoid back strain, and to insure safety to the unit and yourself, we suggest you may need a helper to remove the running deck assembly from box.

### List of parts

Before assembling your treadmill, make sure that you have all the following items:

1. Eight 5/16" x 3/4" bolts-lift post
2. Eight 5/16" nylon washers-lift post
3. Eight 5/16" washers-lift post
4. Four 1/4" x 1 1/4 " bolts-handrail / handlebar holder
- 4A. Two 5/16" bolts-handrail clamp (for 3100L only)
5. Two 1/4" x 1/2 " screws-water bottle holder
6. One water bottle holder
7. One safety key
8. One hex Allen wrench
9. One hex Allen wrench with handle
10. One combination wrench
11. Three fuses
  - a. 15A (100V/120V use) or 10A (200V/240V use)-Electronics and Motor
  - b. 4A-Incline system
  - c. 3 A (100V/120V use) or 2A (200V/240V use)-Drive board

If any items are missing, contact your authorized service dealer.

**IMPORTANT:** The packing for this treadmill was designed to protect it during shipment. Please store the original packing in a safe place in case you need to ship the treadmill in the future.

## Step by step instructions

The following steps explain how to assemble your treadmill. Please read every step thoroughly, and follow the directions completely to ensure correct assembly.

1. There are important parts enclosed inside of the Styrofoam, please check Styrofoam compartments before discarding. Make sure all packing materials are removed from the treadmill deck.
2. Lay the treadmill on its side. Make sure the running belt is position in the tracks of the two BELT ALIGNMENT ROLLER underside of the machine (see Fig. 1 ).

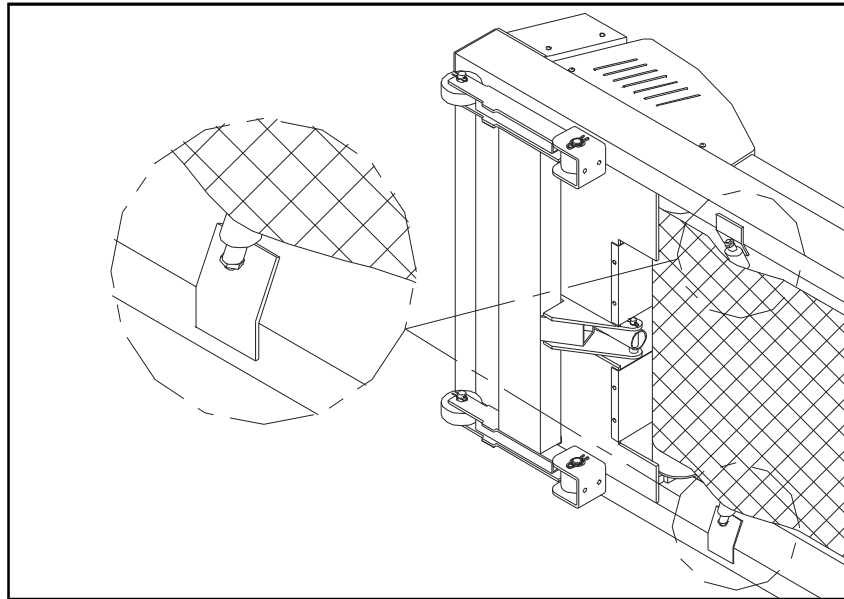

Fig.1

3. Then, place the treadmill on a level, flat surface.
4. Insert the two lift posts into their respective sockets and secure with four bolts and washers provided on each side (see Fig. 2).

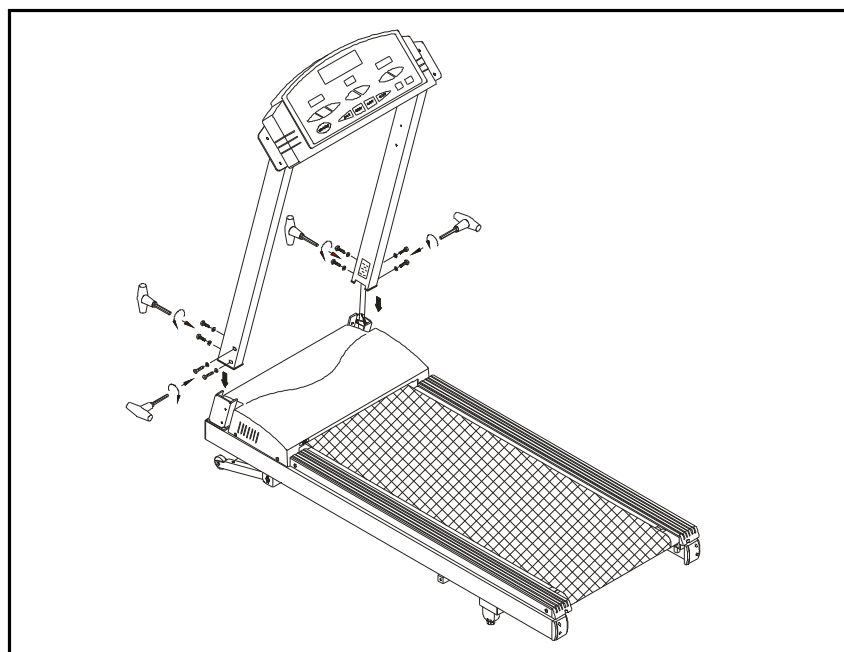

Fig.2

5. Attach the handlebar or the end of the handrails to its holder.

Making sure that the notch in the handlebar or handrails fit into the holder channel. Do not tighten the bolts yet (see Fig. 3).

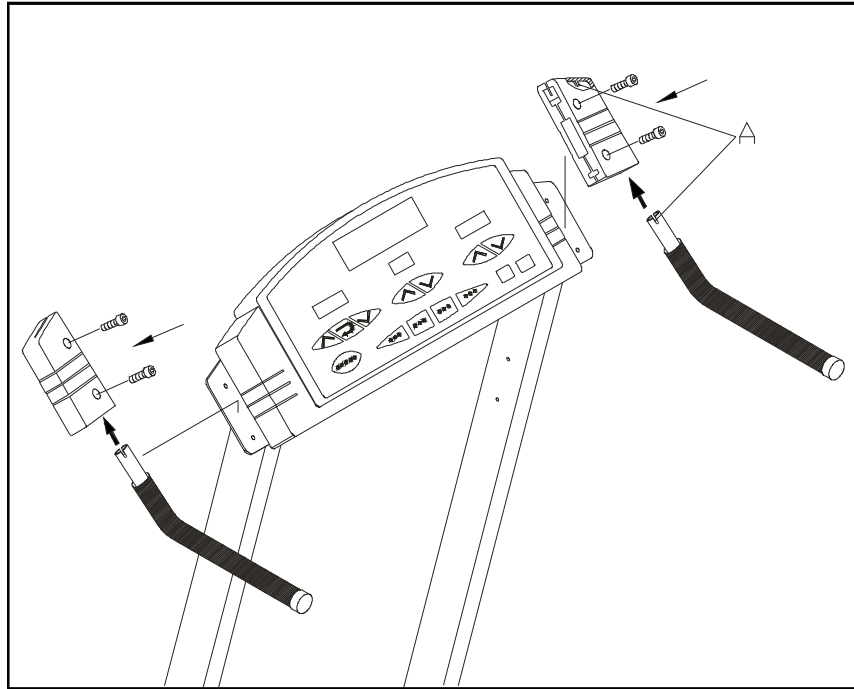

Fig.3

6. Then, secure with bolts provided.
7. If, the unit with handrail, attach the bottom of the handrails with handrail clamps to the treadmill frame secure with one bolt on each side (see Fig. 4). Then, tighten the upper handrails bolts securely.

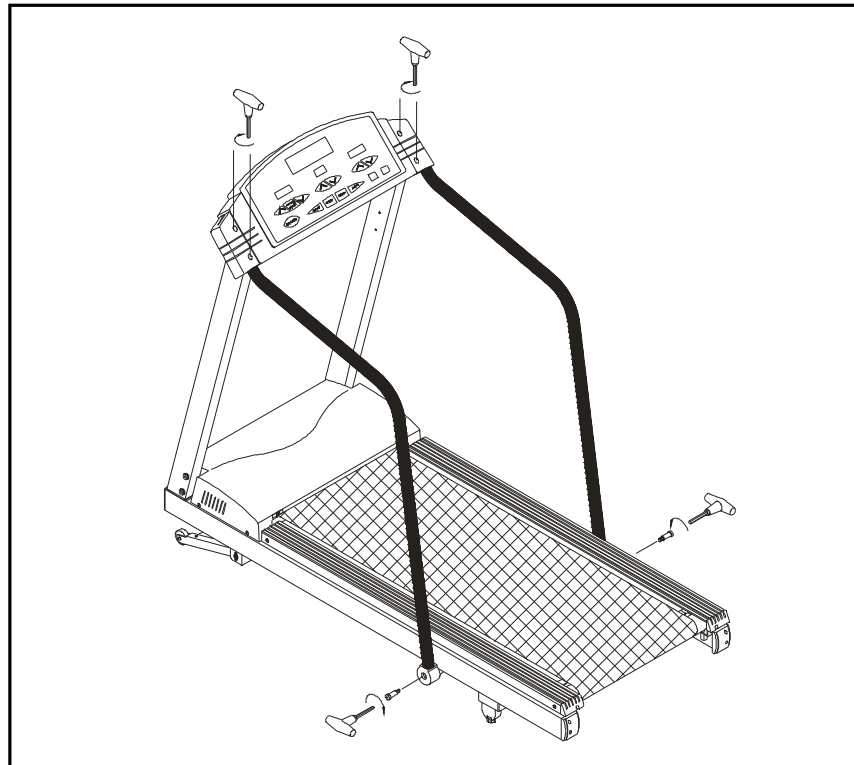
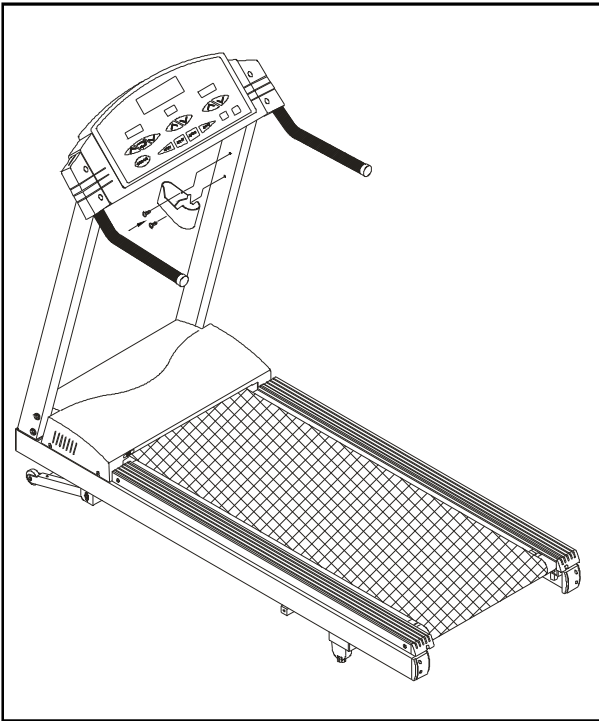

Fig.4



8. Assemble the water bottle/personal stereo holder to the right front post using the screws provided (see Fig. 5).

ITEM:3100



ITEM:3100L

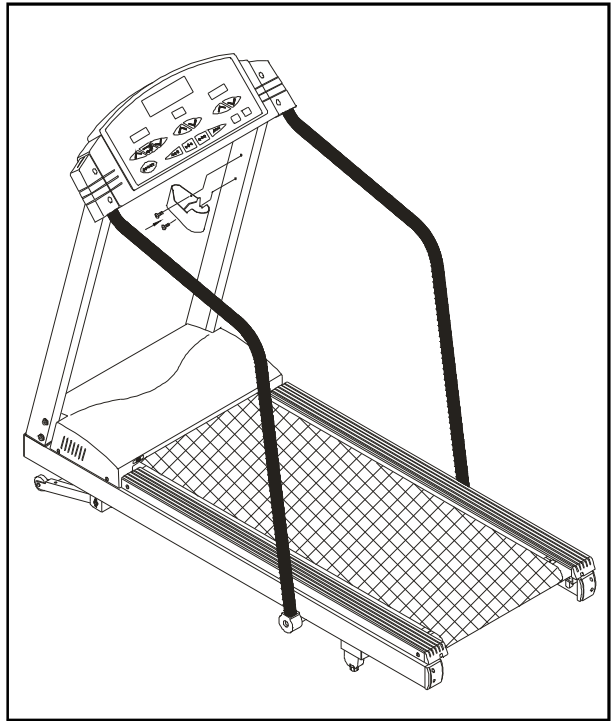

Fig.5

### Floor Level Adjustment

If the treadmill is unsteady on your floor, turn the floor level adjustment on the rear feet of the treadmill. Raise or lower the floor level adjustment to steady your treadmill (see Fig. 6).

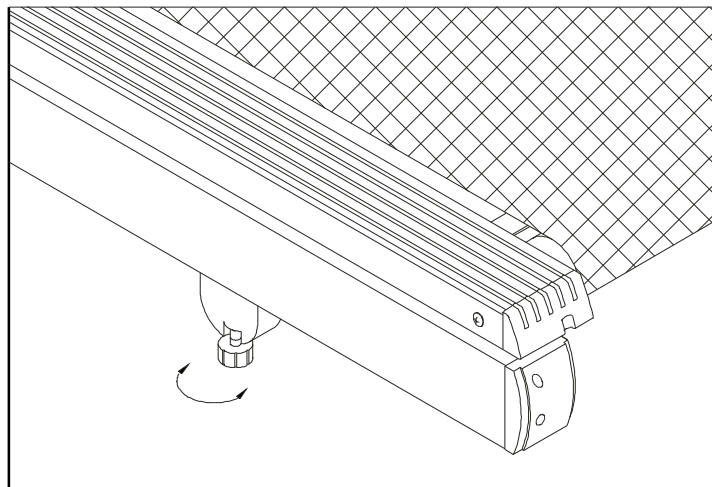



Fig.6

Your treadmill is assembled and ready to use.

## **OPERATING INSTRUCTIONS**

**CAUTION:** DO NOT STAND ON THE BELT WHEN STARTING.

### Safety key

The safety key is required to operate the treadmill (see Fig. 7). The safety key should be used as an emergency stop by clipping the cord to your exercise clothing. Be sure to remove the safety key from your exercise clothing after you have finished your workout, and place it to the key  (NOT IN USE) position for your convenience or store in a safe place to avoid use by children or persons unfamiliar with this treadmill.

Turn on the power switch located on the front of the treadmill. Place the safety key into the "SAFETY KEY" position on the electronics package in order for the unit to function.

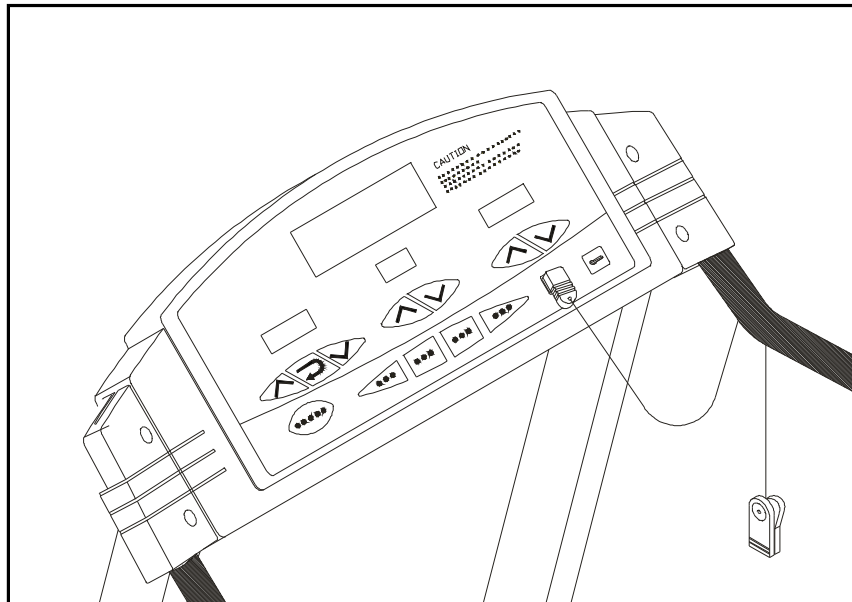

Fig.7

## UNDERSTANDING THE ELECTRONICS PACKAGE

**CAUTION:** DO NOT STAND ON THE BELT WHEN STARTING. Straddle the belt with your feet on the right and left staging platforms.

**IMPORTANT:** Before using the treadmill, the left edge of the running belt must be completely in the green portion of the BELT ALIGNMENT GAUGE, located on the left side of the motor shroud (see Fig.8). Please refer to the "Maintaining treadmill" section "Adjusting the running belt" for further information.

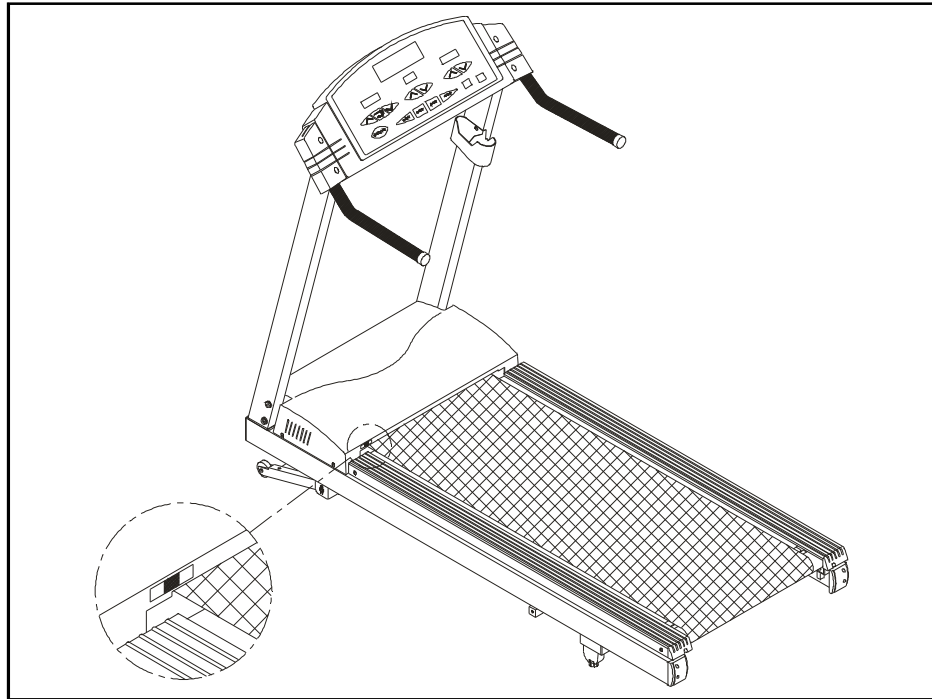



Fig.8

- A. After you turn on the power switch located on the front of the treadmill, the electronics will scroll through with the message "PLACE SAFETY KEY". The treadmill will not function without the safety key in place on the "SAFETY KEY" position of the electronics package. When the unit is not being used, the safety key should be conveniently be placed on the  (NTO IN USE) pad.
- B. After you put the safety key in place, the unit will scroll "MODE ^∨, USER 1-USER 4".
- C. Use the ^ or ∨ keys to select from user 1 through user 4. Once you have made your choice, press "Enter". This will apply your personal information to the workout you are about to begin.

The electronics package automatically recalls the program that was used last. If that is the program you wish to use this time (complete with user information), simply press "Enter" and you may begin. For example, if the last program used was "INTV 2", then pressing "ENTER" will automatically take into "INTV 2".

If you press the MAN'L/SET key, the electronics will display the word "SET".

Press the key again, and you will be in "MAN'L" mode.

Press the INTERVAL key and you will be in "INTV 1". Press INTERVAL again and you will be in "INTV 2".

Press the PROGRAM key and you will be in "PRO 1". Press the key again to change to any program 1-8.

#### MANUAL mode:

- A. When "MAN'L" appears in the display window, and you will be in the MANUAL mode.
- B. Press the SPEED  $\wedge$  or  $\vee$  keys, and this will start the motor. The speed range is 0-11 MPH (0-18 KPH). Press speed  $\wedge$  key to increase and press  $\vee$  key to decrease the speed.
- C. Press the INCLINE  $\wedge$  or  $\vee$  keys, and this will raise and lower the treadmill. The INCLINE range is 0-15%.
- D. Press the MODE  $\rightarrow$  key, and this will scroll you through the different modes on the smaller display window. With each press of the MODE  $\rightarrow$  key, the display will alternately show TIME, DISTANCE, CALORIES, SCAN. The first time you enter the MANUAL mode, TIME will automatically show first.
- E. When using the MAN'L mode the large LED readout will show "MAN'L".

#### SET mode

- A. Press MANUAL/SET keys, the "MAN'L" will show in the display. Press key once again, the "Set" appears in the Electronics display, press "ENTER".
- B. You will be prompted to choose between "MALE/FEMALE". Use the  $\wedge$  or  $\vee$  keys to select your choice, then press the enter key to record that choice.
- C. Then, you will be prompted to choose MPH or KPH.
- D. Use the  $\wedge$  or  $\vee$  keys to select either choice, then press ENTER to record that choice.
- E. Next you will be prompted to "ENTER WEIGHT". After 4 seconds, the last setting weight will appear. Use the  $\wedge$  or  $\vee$  keys to change the weight. Pressing the key once changes the weight 1 LB or 1 KG.

Holding the key down will change the weight 10 LB or 5 KG every 0.5 seconds. The weight range available is 50LB-300LB and 22 KG-140 KG. Then press ENTER to record them.

## INTERVAL mode

### A. INTERVAL 1:

1. Choose "INTV", and the LED will display INTV 1. If this is the interval program you want, then press "ENTER". The message: "ENTER REST SPEED & INCLINE & TIME" will scroll through. REST will appear in the center display.
2. The default of REST information, 2.0 mph or 3.2 kph & 60 seconds & 0% will be displayed in the center of windows. If you accept the default setting, simply press "ENTER".
3. You can use the speed  $\wedge$  or  $\vee$  keys to change your desired speed.
  - a. 60 seconds will be displayed in the TIME display. You can use the  $\wedge$  or  $\vee$  keys to change the time. Time can be set from 60-255 seconds.
  - b. 0% will be displayed in the INCLINE display. You can use the incline  $\wedge$  or  $\vee$  keys to change the incline.
  - c. Once you have set your desired REST levels, press ENTER to record them.
4. After the REST levels have been set, the display will read ENTER WORK SPEED & INCLINE & TIME will scroll through. WORK will appear in the center display.
5. The default WORK level 30 seconds & 4.0 mph & 5% will show in the center of windows. Please refer to the REST setting instruction to alter the WORK settings. Once you have set your desired WORK levels, press ENTER to record them.
6. After you have set your desired WORK levels, you will be prompted to ENTER TOTAL TIME. The default of total time will appear in the display. Use the  $\wedge$  or  $\vee$  keys to set your desired total time (from 00:00-99:99). Press ENTER.
7. After you have set the TOTAL TIME, the numbers on the right indicate the rest time, while the LED lights on the right and left indicate the REST loads. The taller lights in the center represent the WORK loads.

You may change the REST SPEED by using the  $\wedge$  or  $\vee$  keys under the SPEED display window. You may change the REST INCLINE by using the  $\wedge$  or  $\vee$  keys under the INCLINE display window, and the total time change will not be acceptable.

TOTAL TIME is displayed in the smaller central window. When the countdown reaches 00:00, there will be a 10 second beep tone.

8. When the REST TIME is over, the display will show "GOING TO WORK" and then the machine will adjust to the setting you chose for the work loads (speed and incline). If you need to change any of the settings during your workout, please see #3 above. When the WORK TIME is over, the display will show "GOING TO REST", and return to the settings you chose for the rest loads.

9. Press the MODE ↩ key, and this will scroll you through the different modes on the smaller display window. With each press of the MODE key, the display will alternately show TIME, DISTANCE, CALORIES, or SCAN.

10. Keep in mind that the limits are as follows:

SPEED is from 0-11 mph (0-18 kph).

INCLINE is from 0-15%.

Rest/Work TIME is from 60-255 seconds.

#### B. INTERVAL 2:

Press the INTERVAL key and you will be in "INTV 1". Press INTERVAL again and you will be in "INTV 2".

1. Interval 2 allows you to design your own personalized workout program. There are eight programmable segments in Interval 2. When you have switched to INTV 2, press ENTER, and you will be prompted to ENTER SEGMENT 1 SPEED & INCLINE & TIME.

S 1 will appear in the LED window.

Use the SPEED ^ or v keys to set your desired speed.

Use + or - keys to set your desired TIME. Time can be set from 0-99 minutes.

You can use the INCLINE ^ or v keys to set your desired incline.

2. For Segments 2-8, please refer to the instructions above. Once all segments are set, press ENTER one last time, and your own personalized program, under INTV 2, will be recorded.

3. Press the MODE ↩ key, and this will scroll you through the different mode on the smaller display window. With each press of the MODE key, the display will alternately show TIME, DISTANCE, CALORIES or SCAN.

## PROGRAM mode

- A. There are a total of eight (8) programs in this machine.
- B. Press the PROGRAM key and you will be in "PRO 1". Press the key again to change to any program 1-8.

The course profile for each PROGRAM is as follows:

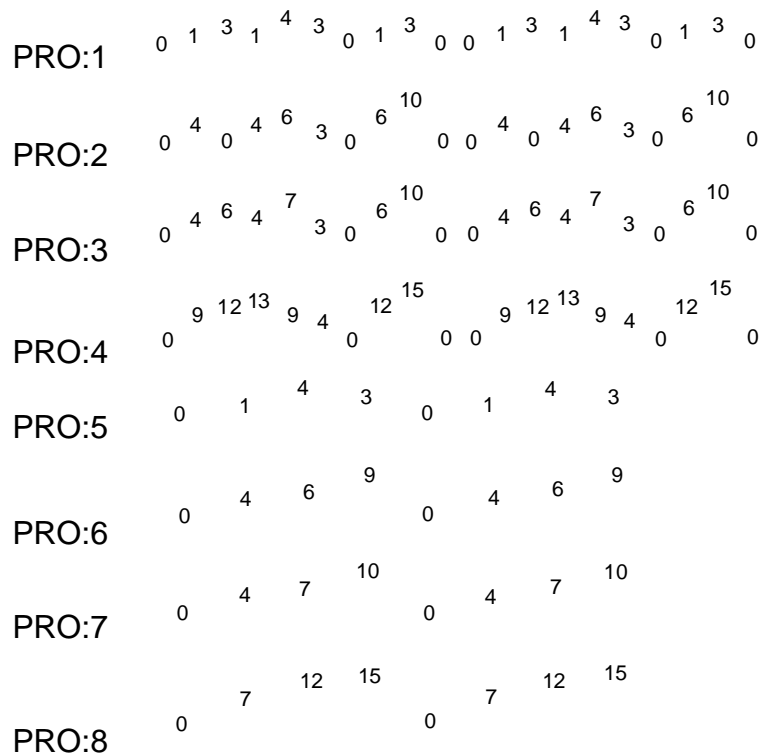

- C. When you have chosen the one you want, press the ENTER key. You will be prompted to SELECT DIST or TIME. Use the  $\wedge$  or  $\vee$  keys to switch between DIST and TIME, then press ENTER to select your choice.
- D. Use the + and keys to select your desired distance or time, then press ENTER.
- E. The program will be displayed in the large central LED window, and will begin when you start the unit using the speed  $\wedge$  or  $\vee$  keys. During these programs, you control the speed, and the unit will automatically switch between elevation percentages, giving you the feeling of running on hills or level ground.
- F. Use the MODE  $\rightarrow$  key to switch the smaller center display between TIME, DIS, CAL, or SCAN.
- G. When your desired TIME or DIST is reached, a beep tone will sound for 10 seconds, after which the machine will begin to count up again.

## PAUSE mode

- A. Every MODE of the treadmill (intervals, manual, programs, etc.) can use the special PAUSE key. This allows you to stop in the middle of your workout to answer the phone, get a drink or do something else. Then, when you are finished, you can pick up your workout where you left off.
- B. After you press the PAUSE key, the word PAUSE will appear in the central LED, and the machine will stop, though your position in every program (SPEED, INCLINE, CALORIES, etc.) will be remembered.
- C. When you return to the treadmill, simply press PAUSE again. The electronic package will show "START" on the main window after 7 seconds and your workout will be continued. The speed of the treadmill will gradually return to the setting prior to the PAUSE.

NOTE: When the machine is paused, you may remove the safety key for extra security, so no one may operate the machine in your absence. Remember to replace the safety key before you press PAUSE to continue your workout.







CAUTION: If you remove the safety key before pressing pause, all information concerning your workout will be lost.

## General Remarks





- A. Should you not remember to press ENTER to accept your choice, after few seconds you will be reminded to PRESS ENTER.
- B. If you use the fast manual mode to operate the machine, no user and INTERVAL, PROGRAM mode information will be entered.



## KEY FUNCTIONS:



**SPEED**   : Use the speed   key to adjust your desired speed. The speed range for the treadmill is from 0-11 mile (0-18 km). Press the speed  key to increase the speed and press the Speed  key to decrease the speed.

**INCLINE**   : Use the INCLINE   key to raise or lower the treadmill. The incline range for the treadmill is from 0%-15%.



**MODE**  : When you place the safety key in its place, the electronics package will automatically access into MODE  function. Press the mode  key, and this will scroll you through the different modes. With each press of the MODE  key, the display will alternately show TIME, DIST (Distance), CAL (Calories), SCAN or PULSE.

  key: These keys are used to choose the desired TIME or DISTANCE.



**SAFETY KEY:** Turn on the POWER switch located on the front of the machine. Put the SAFETY KEY on the "SAFETY KEY" position of the electronics package to operate the treadmill.

 : After your workout, place the safety key on  (NOT IN USE) position (NOT IN USE) for your convenience. Then turning the power switch off.

### What each of the categories means:

**TIME:** The range available in TIME mode is 00:00-99:59 minutes. Use the MODE  key to select the time mode. When TIME LED is lit in the display, use the   keys to adjust the desired time.

The electronics package will BEEP for 10 seconds when your desired time is reached, then will start to count up if your workout continues. Each press of the key change the time by 1 minute.

**DIST:** The distance of the treadmill will register goes from 0-99.99 miles or 0-999.9 kilometers. Use the MODE  key to select the DIST mode. When DIST LED is lit in the display, use the   keys to adjust the desired distance.

Each press of the key changes the distance by 0.1 mile or 0.1 km.

The electronics package will BEEP for 10 seconds when your desired distance is reached, then will start to count up if you workout continues.

**CAL:** This readout gives you the amount of calories burned, the range of calories is from 0-999.9CAL.

**SCAN:** The SCAN will result in the display alternation between Modes readouts every 4 seconds.

## **RUNNING ON THE TREADMILL**

Now, that you have become familiar with your treadmill's operation and are ready to exercise:

1. Plug the treadmill into a standard outlet. Turn on the power switch located on the front of the machine.
2. Straddle the belt with your feet on the right and left staging platforms. Place the SAFETY KEY on the "SAFETY KEY" position of the electronics package to operate the treadmill.
3. Select your course and follow the scrolled messages. You may also PRESS the SPEED keys to begin.
4. Press speed  $\wedge$  key until you reach 1.5-2.0 mph/2.5-3.5 kph or a comfortable walking speed, keep both hands on the handrails, and walk for a few minutes to get comfortable with your treadmill.
5. After you are walking in an easy, relaxed, and steady fashion, now release your grip on the handrails, and let your arms swing freely and naturally.
6. When you feel comfortable walking, you may wish to jog. Hold the handrail with one hand, use the other hand to increase the speed for jogging.
7. Remember to hold the handrail when using the control panel on the electronics package, or to catch your balance when slowing down or stopping, and for dismounting.
8. When you have finished your workout, remove the SAFETY KEY from "SAFETY KEY" to  (NOT IN USE) position. After completing the proper amount of time to cooldown before the machine completely stop.

## **GUIDELINES FOR EXERCISE**

### How long should I exercise?

The duration of your exercise session is dependent on your fitness level. In general, it is recommended that you maintain your heart rate in the training zone for at least 10 minutes to realize an aerobic benefit. As your fitness level increases, you will be able to maintain your heart rate in the training zone for longer periods: usually between 20 and 30 minutes.

When first starting your workout, take the first several minutes to warm up, then slowly increase your workload to bring your heart rate into your specific training zone. At the end of your workout, decrease your workload gradually, then exercise lightly as a "cool down".

### How often should I exercise?

Aerobic exercises, to achieve the greatest benefits, should be performed 3-5 times a week. It is important to allow sufficient time, at least 24 hours, for your body to recover after exercise.

## **MAINTAINING YOUR TREADMILL**

Your treadmill relies on low friction for peak performance. The treadmill's low friction operation is dependent on keeping the unit as clean as possible. See "Cleaning the Treadmill" for more information.

Proper belt alignment is also important for proper operation of the treadmill. See "Adjusting the Running Belt" for more information.

### Cleaning the treadmill

**CAUTION:** Turn off unit and disconnect AC cord before cleaning.

Regular cleaning is recommended to keep your treadmill running at peak performance.

Before your workout, use a dry cloth to clean the staging platform, exposed slider deck, and under the belt as far as you easily reach. This removes any dirt or dust which might enter the slider area and compromise the unit's running efficiency.

To clean the plastic parts, use a mild detergent and make sure the unit is completely dry before operating. On the running surface, use a soft nylon scrub brush. Do not use water to clean the belt or running surface, or to clean the electronics package. Should water, for some reason, get on the electronics package, immediately blow dry the electronics package.

It is recommended that you keep all liquids away from the unit during operation. Spillage of liquids onto or into the machine will void the warranty.

## Adjusting the running belt

Your treadmill comes with a belt alignment gauge located on the left side of the motor cover (see Fig. 9). The edge of the running belt should be in the middle of the green portion of the gauge. If the belt edge is in the green area, the belt does not need adjusting. If the right edge is in the red portion, the belt needs adjusting immediately.

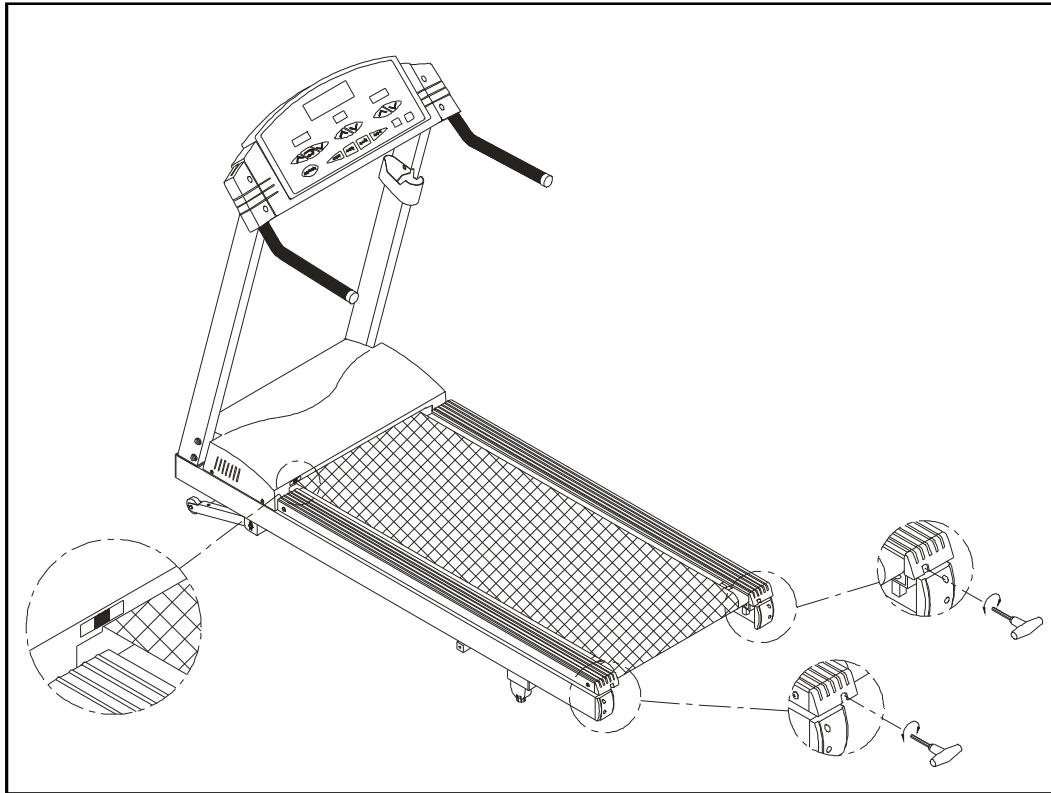

Fig.9

The belt is properly aligned at the factory. However, during shipping and handling or by use on an uneven surface, the belt may move off center. Therefore, it is important that you check the belt's alignment before using the treadmill.

The correct alignment of the running belt is critical for the smooth operation of the treadmill.

**CAUTION:** DO NOT ALLOW ANYONE TO WALK ON RUNNING BELT DURING THIS PROCEDURE.

Failure to realign the belt could result in tearing or fraying of the belt, which is not covered in the warranty. Please follow the adjustment procedure listed below :

1. Turn on the power switch located on the front of machine. Place the SAFETY KEY on the "SAFETY KEY" position.
2. Press the SPEED  $\wedge$  key to increase the speed until the speed registers 2.0mph / 3.2kph on the digital display.
3. While the unit is running at 2.0mph/3.2kph, determine where the belt is in relation to the belt alignment gauge.
4. Should your belt be in the wrong color range, follow the steps below to return the belt to the "safety zone":
5. If the belt is in the left red zone: Turn the left belt adjustment bolt located at the rear of the treadmill clockwise 1/4 turn at a time, using the hex Allen wrench. Then turn the right belt adjustment bolt counterclockwise 1/4 turn. Let the treadmill run 30 seconds, then check the position of the belt in the color gauge. If the belt still has not returned to the green safety zone, repeat with another 1/4 turn until the belt has returned to the middle of the green area. Do not turn adjusting bolt more than 1/4 turn at a time.

If the belt is on the edge of the green color, please adjust it so it is in the middle of the green color. You may turn the adjustment nut less than 1/4 turn at a time.

6. Conversely, if the belt is in the right red zone, turn the right belt adjustment nut clockwise 1/4 turn, then turn the left adjustment bolt counterclockwise 1/4 turn. Then let the treadmill run at least 30 seconds, check the position of the belt in the color gauge. If it still has not returned to the green safety zone, repeat with another 1/4 turn until the belt has return to the middle of the green area. Do not turn adjusting bolt more than 1/4 turn at a time.
7. When the belt is back in the green "safety zone", you can continue your regular use of the treadmill. Slowly increase the speed of the unit to 5.5 MPH (9 KPH), and let it run for at least 45 seconds.

Periodically monitor the position of the belt to ensure peak performance:

When you are using the treadmill, if you feel a pause in the belt with each foot plant the belt is too loose. Stop the machine, check the belt tension, left the running belt off the deck in the middle (see 10 & 10-1). There should be about 15m/m (5/8") or 3-5 kgs of "give" in the belt. If there is too much (see Fig. 10-2), then adjust both rear roller bolts clockwise 1/2 turn at a time (see Fig. 10-3).

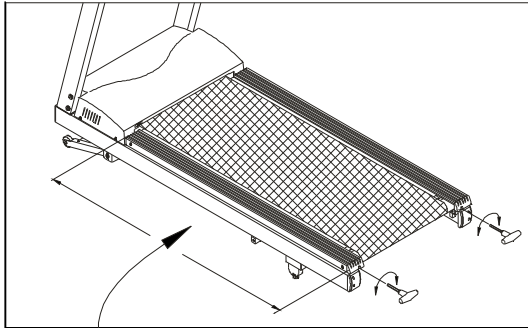

Fig.10

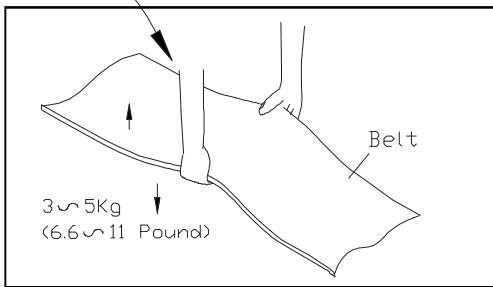

Fig.10-1

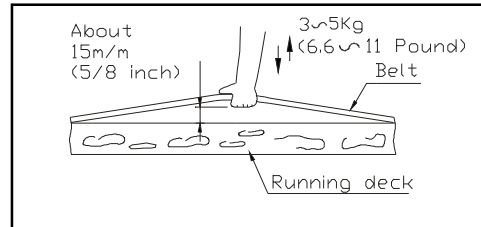

Fig.10-2

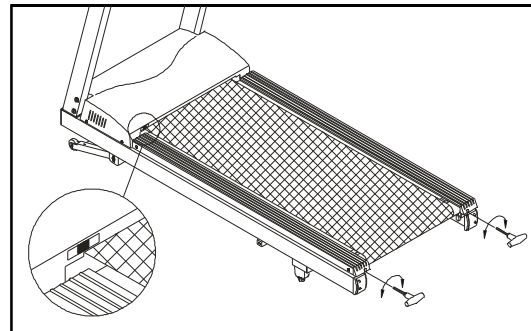

Fig.10-3

Then, try the belt tension again, if more adjusting is required, give both adjusting bolts another slight turn. Do not adjust over 2 fullturns.

Conversely, if the "give" in the belt is too tight, adjust both rear roller bolts counterclockwise 1/2 turn at a time (see Fig. 10-3).

**CAUTION:** To avoid injury, special care must be taken when adjusting the running belt. Turn off the treadmill while adjusting or working near the rear rollers. Remove any loose clothing or shoe laces and tie back your hair. Be very careful to keep your fingers or any other objects clear of the belt and rollers.

The treadmill is designed to carry specific weights at specific speeds. The treadmill will not stop immediately if any object becomes caught in the belt or rollers.

Over tightening of the belt causes damage and premature failure of the precision bearings in the front and rear rollers.

## **TROUBLE SHOOTING:**

**CAUTION: SHUT OFF UNIT AND DISCONNECT AC CORD BEFORE MAKING ANY REPAIRS OR MODIFICATIONS.**

### **"ERR" messages**

Note: If the electronics display shows "ERR 1, ERR 3, ERR 6 , ERR 7 or ERR 10", please turn off the POWER switch on the front of the machine. Allow the unit rest for 5 seconds, then turn on the power switch begin operation again. Should the electronics package display "ERR" again, please refer to the following section for more information. OR, please contact your dealer for further instructions.

ERR 1- The optical switch mounted on the motor is not receiving the signal reflected from the tachometer wheel. Please contact your dealer.

ERR 3- The user is running faster than the belt. Please turn the POWER switch off, allow the machine to rest for 5 seconds, then try normal use again.

ERR 6- The unit's incline system is not responding, please replace the 0.5A ( 200-240V) or 1A (100-120V) fuse located underneath the treadmill, make sure your area standard voltage prior to replacement.

The incline system fuse holder is located under the frame at the front of the machine (see Fig. 11).

To remove the fuses, push on the fuse holder and then turn the holder counterclockwise and the fuse holder with fuse will protrude.

Remove the damage fuse and insert a new fuse, push the fuse and holder in, turning clockwise to secure it.

If the unit still refuses to respond, please contact your dealer for more information.

ERR 7- Once you turn on the machine, the computer display shown the ERR 7. The computer receiving the signal reflected from VR incorrectly, that means the wires disconnected.

Make sure the 16 pin cable connector inside the right front post plug into its socket at the base of the treadmill is connected securely, please refer to Fig. 2.

If, after performing the above steps, the display still shows ERR 7, please contact your dealer for further information.

ERR 10- The treadmill suddenly speeds up to maximum speed while you are using it and shuts off. Please contact your dealer for more information.

## Blank display

1. If you turn on the POWER switch and there is no light:
  - a. Check if the power cord is plugged securely into the wall socket.
  - b. Check that the power switch on the front of the unit is in the "ON" position. The power switch should be lit.
  - c. If the power switch is not lit, replace the fuse. Please refer to the ELECTRONICS PACKAGE AND MOTOR FUSE FAILURE section for more information.
  - d. If there is still no display after completing the above steps, please contact your dealer for more information.
2. The power switch is lit, but no words appear on the display:
  - a. Make sure the cable connectors inside the right lift post at the base of the readmill is firmly in its sockets. Please refer to the Fig. 2.
  - b. If the display is no words, then the fuse on the driver board need to be replaced, please check with your dealer for further information.

## Fuse Failure For Electronics Package And Motor

If nothing is displayed on the electronics package, please check the POWER switch located on the front of the treadmill. If it is unlit, then the fuse is damaged and must be replaced.

**CAUTION: MAKE SURE THE TREADMILL PLUG IS REMOVED FROM OUTLET BEFORE REPLACING THE FUSE.**

There are two fuse holders are located at the front of the treadmill frame, the left 4 amp fuse holder is for the INCLINE SYSTEM, and the right fuse holder 15 amp/100-120 volts (or 10 amp/ 220-240 volts) is for the Electronics Package and Motor, please make sure to check your standard voltage prior to fuse replacement (See Fig. 11).

To remove the fuse for the electronics package and motor, push on the fuse holder and then turn the holder counterclockwise and the fuse holder with fuse will protrude. Remove the damaged fuse and insert a new fuse, pushing the fuse and holder in, then turning clockwise to secure the fuse holder (see Fig. 11-1 ~ 11-3).



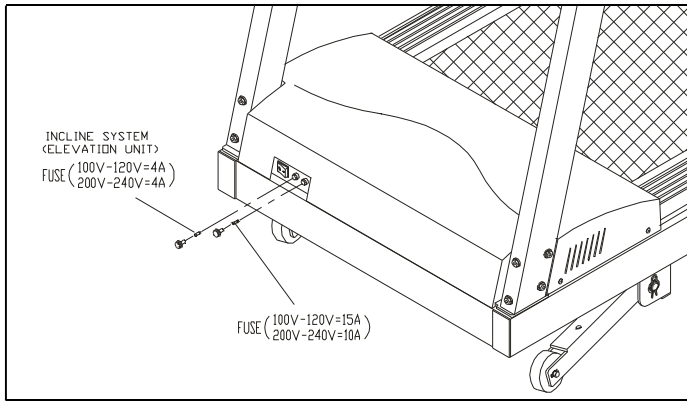

Fig.11

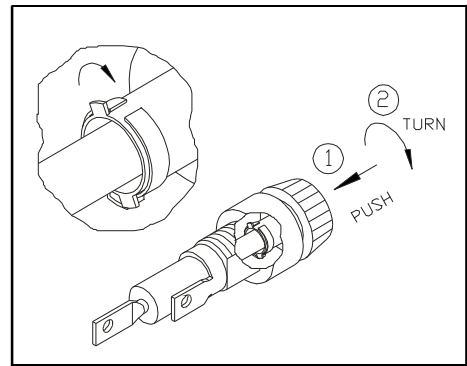

Fig.11-2

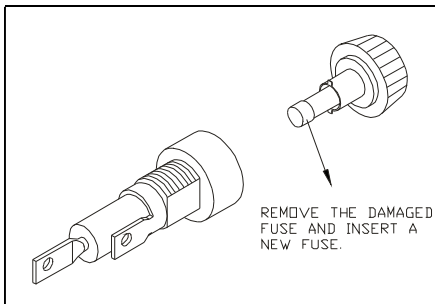

Fig.11-1

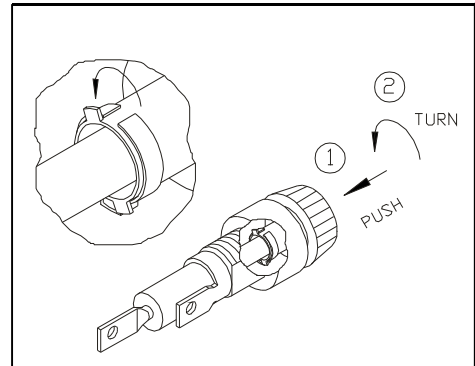

Fig.11-3

If the unit's electronics package or motor refuses to respond after changing the fuse, please contact your dealer for more information.

### Fuse Failure For Incline System

Should the incline system refuses to respond, but there is power to the electronics package and it remains operable, please replace the incline system fuse.

The 4amp fuse is for the Incline system. To remove the incline system fuse, push on the fuse holder and then turn the holder counterclockwise and the fuse holder with fuse will protrude. Remove the damaged fuse and insert a new fuse, pushing the fuse and holder in, then turning clockwise to secure the fuse holder (see Fig. 11-1 ~ 11-3).

If the incline system refuses to respond after changing the fuse, please contact your dealer for more information.

## Fuse Failure For Drive Board

NOTE: If you are not a technician or do not have expert knowledge of this machine.  
Please do not attempt to replace it.

If there is nothing displays on the electronics package, and the POWER SWITCH located on the front of the treadmill is lit, then the fuse is damaged on the drive board and must be replaced.

The fuse holder 3 A (100V/120V) or 2A (200V/240V) for the drive board is located on the frame at the front of the treadmill (see Fig. 12).

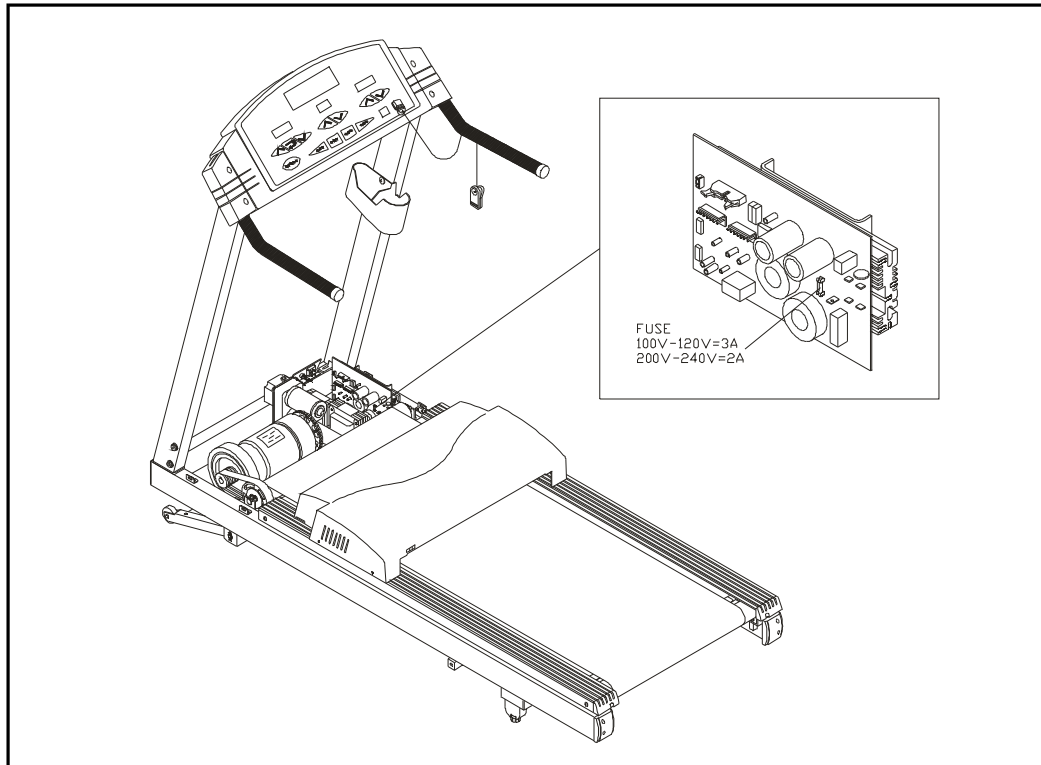
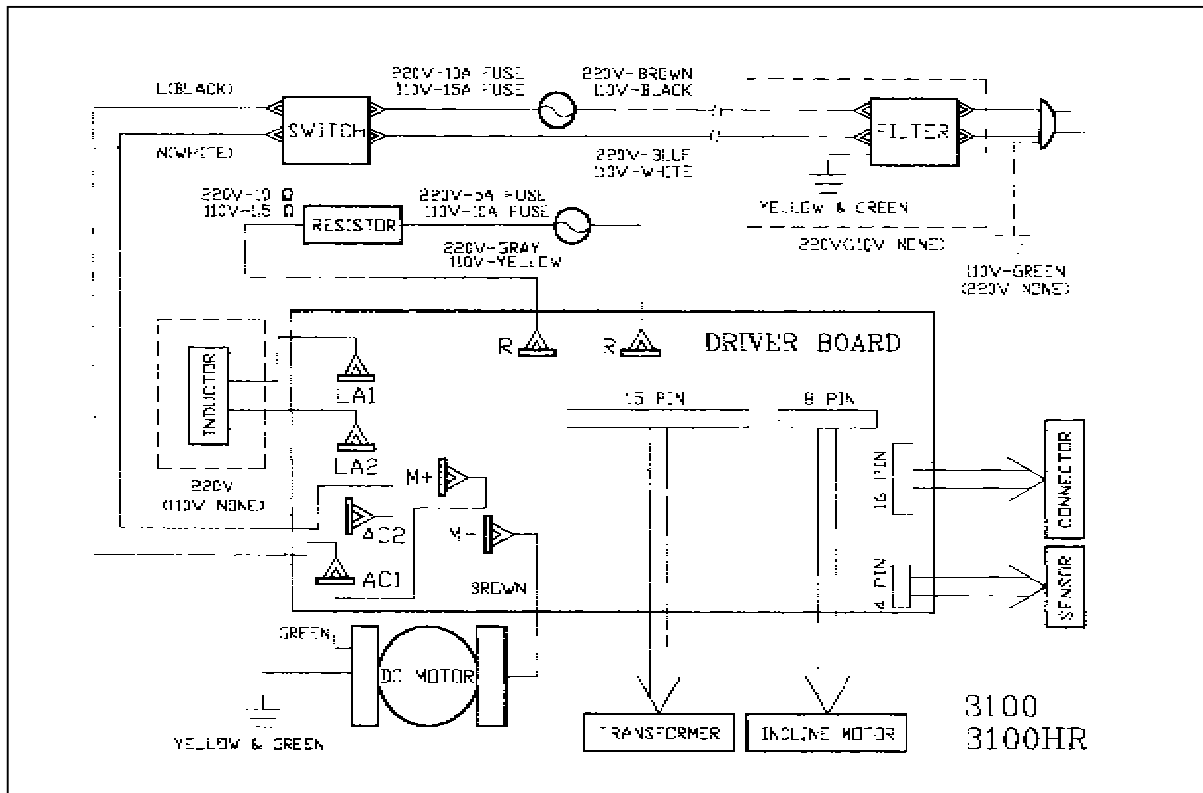

Fig.12

## Wiring Schematic:



**Your Authorized Distributor**

50LB-300LB and 22 LG-140 LG.